

SUBMITTAL SHEET

JOB NAME _____ ITEM TAG _____

JOB LOCATION _____ PART NUMBER _____

CONTRACTOR _____ DATE _____

ENGINEER APPROVAL _____ DATE _____

LEAD-FREE COMPRESSION END BALL VALVE

Model T-1009NL

Lead-free design is suitable for all no-lead potable water installations, in full compliance of all lead-free plumbing laws.

Tubing compression connections permit easy, convenient, lead-free compliant replacement of a worn, leaded valve, without the need for sweating.

Quarter-turn, positive-shutoff full port design, make the T-1009NL the ideal replacement for a leaking multi-turn, drip-tight, reduced port gate valve.

Self-cleaning chrome-plated ball resists mineral build-up and scaling typically found in harsh, varying water conditions.

Maintenance-free dual O-ring stem design.

Bottom-loaded blowout-proof stem.

Available in nominal sizes 1/2" to 1".

Working Pressure, Non Shock (PSI)

Cold working pressure (CWP): 600 p.s.i.
Saturated steam (WSP): Not suitable for steam service

DIMENSIONS

Size	A	B	C	D	C.V.*
1/2"	2.96	1.14	.59	3.04	14.20
3/4"	3.37	1.70	.79	3.74	28.60
1"	3.83	1.80	1.00	3.74	56.40

- Third-party tested and certified in compliance with U.S. Federal Public Law 111-380 (National lead-free plumbing law).
- NSF certified to ANSI / NSF Standard 61 Annex G: Meets NSF 372 lead content requirements.
- Manufactured in an ISO accredited facility



Pictured T-1009NL

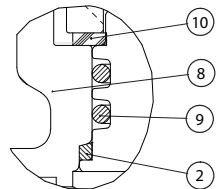
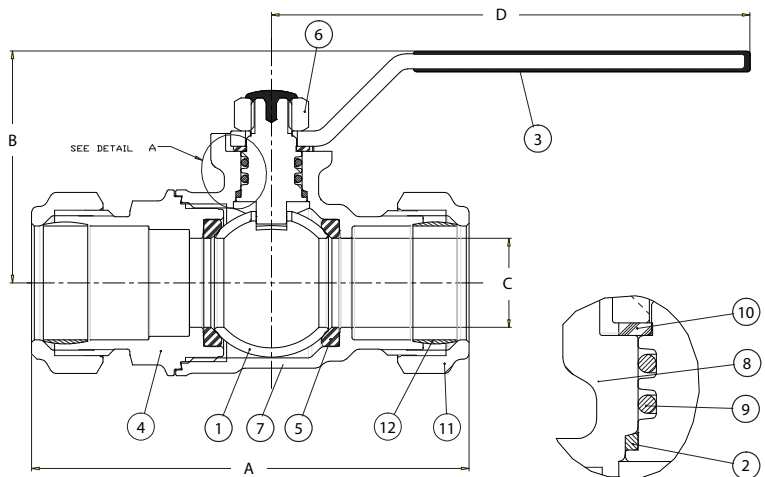

Detail A

Pictured T-1009NL Cut-away

MATERIAL SPECIFICATION		
PART	MATERIAL	SPECIFICATION
1	Ball	Lead-free chrome plated forged brass CW510L UNS C28500
2	Anti-friction thrust washer	TFM PTFE Dyneon*
3	Handle	Dacromet coated steel ASTM A510 UNS G10060
4	End adapter	Lead-free forged brass CW510L UNS C28500
5	Seats (2)	TFM PTFE Dyneon*
6	Handle nut	Dacromet coated steel with PVC resin lock ASTM A510 UNS G10060
7	Body	Lead-free forged brass CW510L UNS C28500
8	Stem	Lead-free chrome plated forged brass CW510L UNS C28500
9	Stem O-rings (2)	Fluoroelastomer Viton**
10	Anti-friction washer	TFM PTFE Dyneon*
11	Compression nut	Forged brass ASTM B124 UNS C37700
12	Ferrule	Tubular brass UNS C26800

*Dyneon TFM is a registered trademark of the 3M Company.

**Viton is a registered trademark of DuPont.